

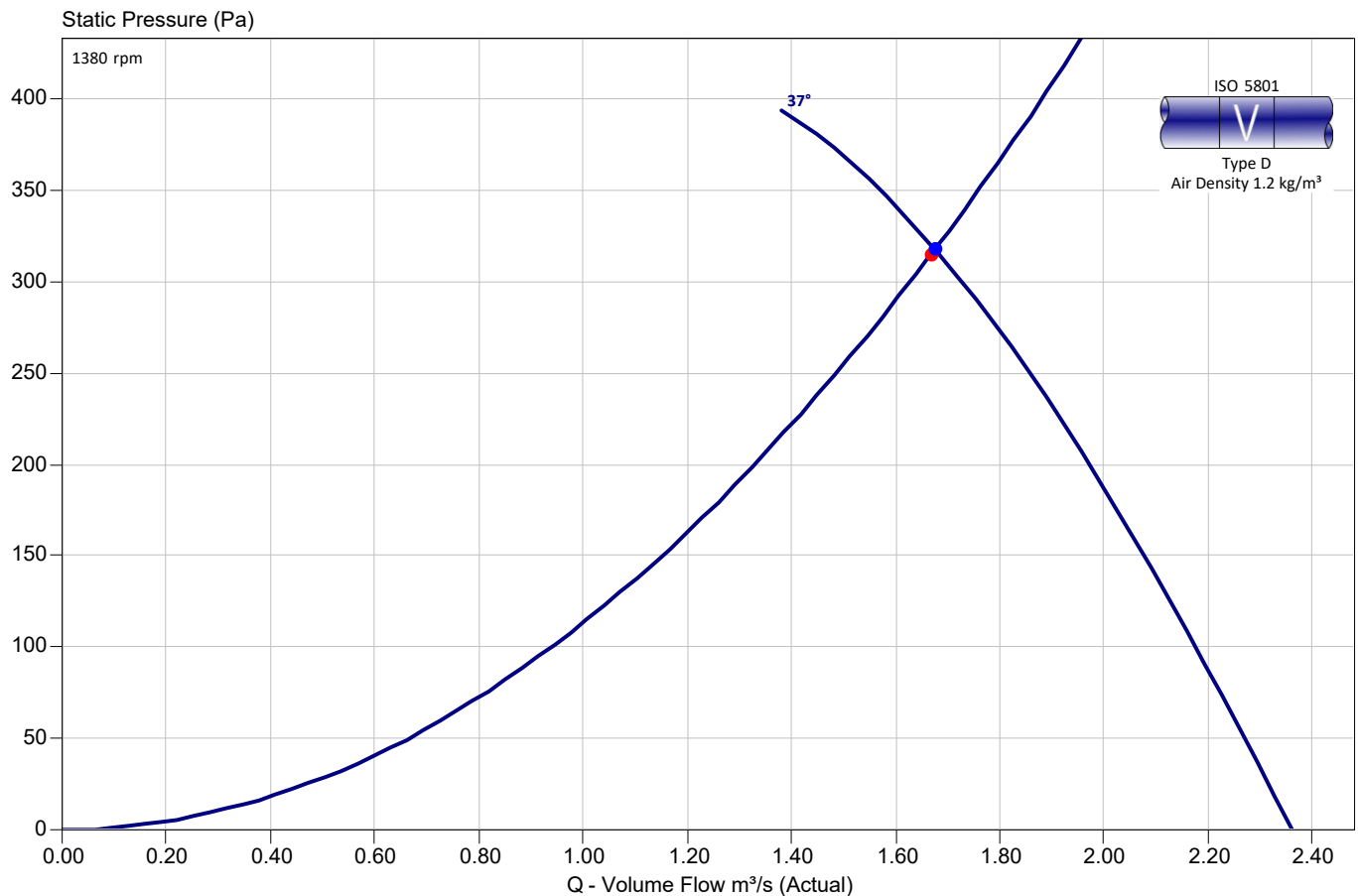

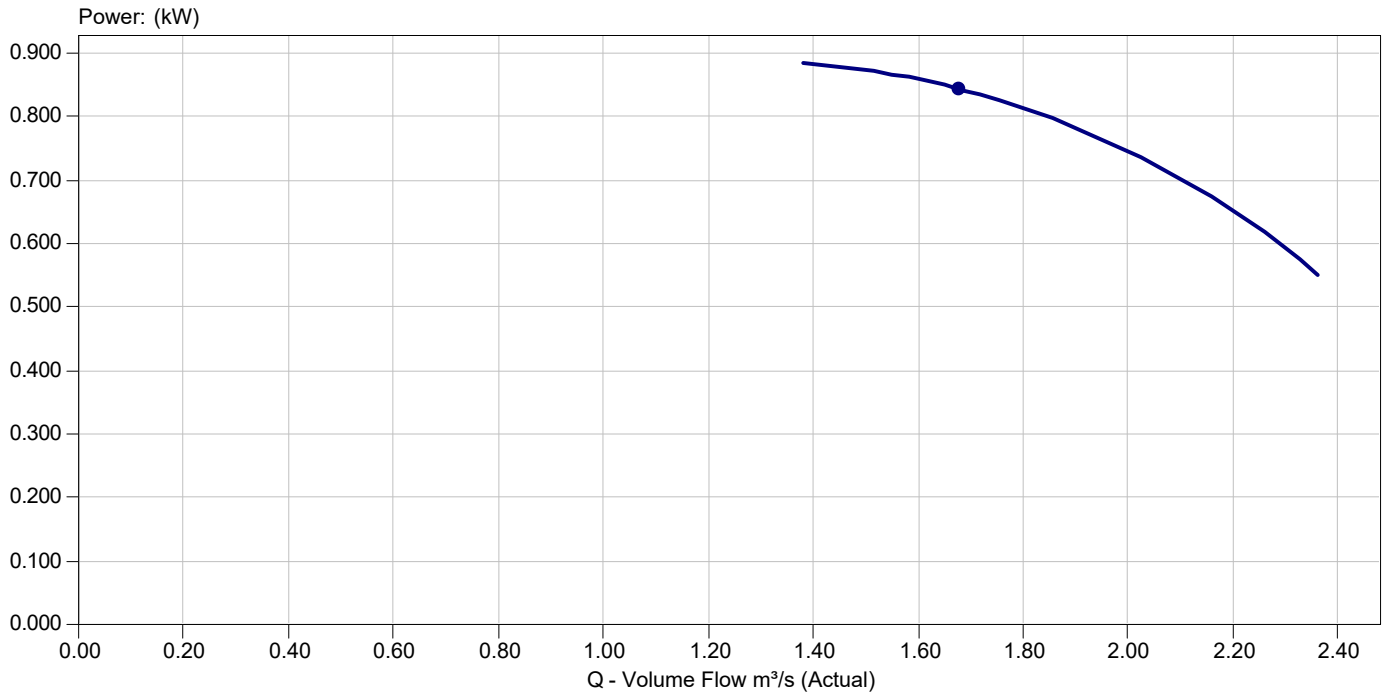

Quotation Number :  
Project Name : Catervent  
Item Reference: :

Project Code : AG-5155-1  
Customer : Catervent  
Date: : Monday, February 20, 2017  
Fan Code : 45-1MaXfan2/16/4/5/37/30





Quotation Number :  
Project Name : Catervent  
Item Reference :

Fan Code : 45-1MaXfan2/16/4/5/37/30  
Customer : Catervent  
Date : Monday, February 20, 2017

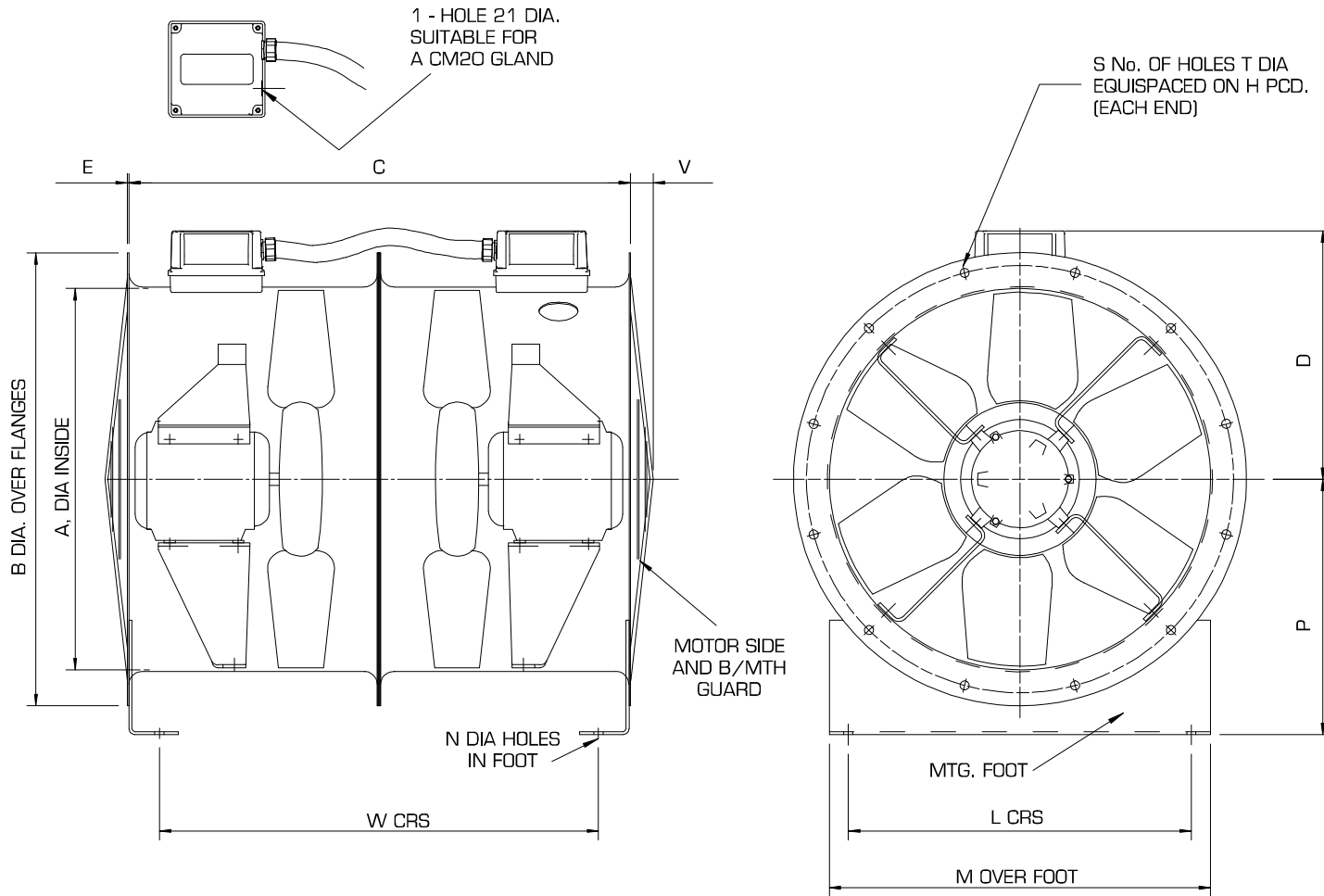

A	450
B	530
C	620
D	306
E	2.5
H	500
L	400
M	450
N	10
P	280
S	8
T	12
W	571
Weight	44

Notes : Dimensions shown in mm / Weight in kg

Reference : Catalogue drawing

This drawing shows dimensions that should be used as a guide only and are subject to change. Certified drawings are available on request.





Quotation Number :  
Project Name : Catervent  
Item Reference: :

Project Code : AG-5155-2  
Customer : Catervent  
Date: : Monday, February 20, 2017  
Fan Code : 2102/450 (c/w Plate+M/S Guard)

